

STAINLESS STEEL TRI CLAMP PRESSURE REGULATOR

RTC

Description	Pressure regulator with flange, piston operated, made of stainless steel		
Media	compressed air, gases or liquids		
Supply pressure	max. 25 bar		
Surface	Electropolished body with roughness Ra < 4 µm on inside wetted surfaces. All metallic parts are machined from the solid bar. No threaded connections exposed to the fluid. The regulator is virtually pocket and sterilizable with steam.		
Adjustment	by adjusting screw RTC-04 and -06, by T-handle RTC-08 and -12		
Relieving function	non-relieving		
Gauge port	locked in standard		
Temperature range	-40°C to 175°C / -40°F to 347°F		
Material	Body, bonnet, piston and inner parts: AISI 316L, AISI 302,	gasket: EPDM or FKM corresponding to FDA	Adjusting spring: C85, nickel plated NIP/Fe 15 µm
	All springs are not in contact with fluid.		

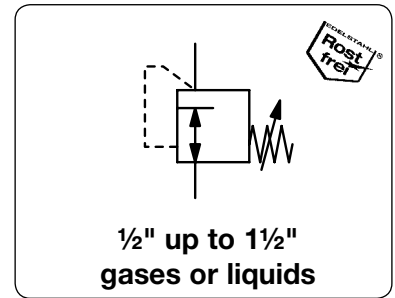

Dimensions				K _v - value	Flow rate	Connection ASME- BPE	Pressure range bar	Order number
A	B	C	ØD					
mm	mm	mm	mm	m³/h ¹	l/min ¹			

Tri Clamp Pressure Regulator							supply pressure max. 25 bar, EPDM for compressed air, gases, liquids and steam	RTC
139	182	57	25	1,2	2200	1/2"	0,2 ... 1,5 0,3 ... 3,0 0,8 ... 8,0	RTC-04A RTC-04B RTC-04D
142	182	57	25	1,2	2200	3/4"	0,2 ... 1,5 0,3 ... 3,0 0,8 ... 8,0	RTC-06A RTC-06B RTC-06D
180	326	75	50,5	11	22000	1"	0,2 ... 1,5 0,3 ... 3,0 0,8 ... 8,0	RTC-08A RTC-08B RTC-08D
182	326	75	50,5	11	22000	1 1/2"	0,2 ... 1,5 0,3 ... 3,0 0,8 ... 8,0	RTC-12A RTC-12B RTC-12D



RTC-04/-06



RTC-08/-12

Special Options, add the appropriate letter

to 200°C	high temperature version	RTC-... X68
FKM o-ring		RTC-... T
EPDM o-ring	FDA approval	RTC-... TD
ammonia	NH ₃	RTC-... 02
nitrogen	N ₂	RTC-... 07
oxygen	O ₂	RTC-... 15
water	H ₂ O	RTC-... W
neutral gas	CO ₂ , Ar, He, H ₂ , CH ₄ , C ₃ H ₈ , N ₂ O	RTC-... XX

Accessories, enclosed

pressure gauge	Ø 50 mm,	0... ^{*2} bar	G1/4	for 1/2" u. 3/4"	MS5002-... ^{*2}
	Ø 63 mm,	0... ^{*2} bar	G1/4	for 1" u. 1 1/2"	MS6302-... ^{*2}
mounting bracket				for 1/2" u. 3/4"	BW45-03S
mounting nut				for 1/2" u. 3/4"	M45x1,5S
mounting bracket				for 1" u. 1 1/2"	BW00-27S

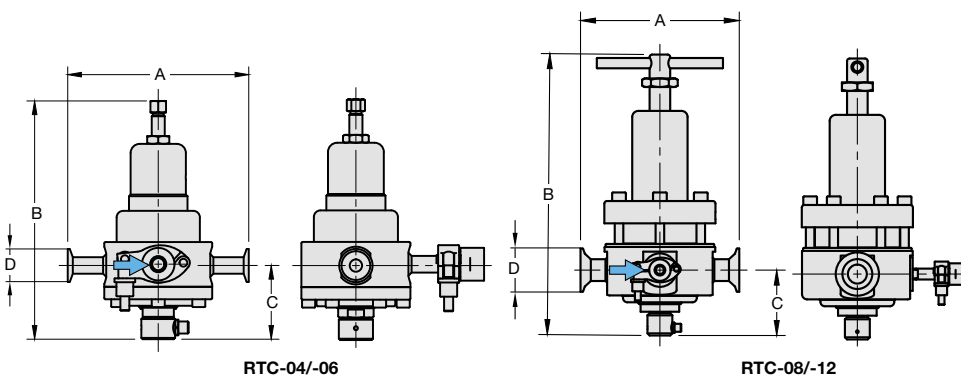

RTC-04/-06

RTC-08/-12

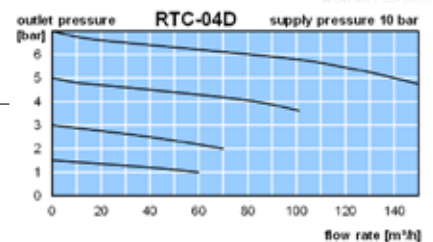
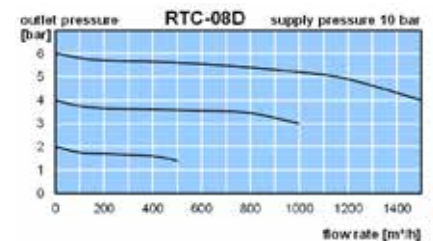

*1 at 10 bar supply pressure, 7 bar outlet pressure and 2 bar pressure drop
*2 02 = 0...2,5 bar, 04 = 0...4 bar, 10 = 0...10 bar

Gauges: see chapter for measuring devices

PDF CAD
www.aircom.net



Order example:
RTC-04A